



**50Ω TERMINATED 18 GHz SMA LATCHING S.P.3 T. SWITCH**

OPTIONS: / TTL DRIVE /SUPP.DIODES

**R F CHARACTERISTICS**

NUMBER OF WAYS : 3  
 FREQUENCY RANGE : 0 - 18 GHz  
 IMPEDANCE : 50 Ohms

|                 |         |         |         |          |
|-----------------|---------|---------|---------|----------|
| FREQUENCY (GHz) | 0 - 3   | 3 - 8   | 8 -12.4 | 12.4- 18 |
| V.S.W.R <=      | 1.20    | 1.30    | 1.40    | 1.50     |
| INSERT. LOSS <= | 0.20 dB | 0.30 dB | 0.40 dB | 0.50 dB  |
| ISOLATION >=    | 80 dB   | 70 dB   | 60 dB   | 60 dB    |
| AVER. POWER (*) | 240 W   | 150 W   | 120 W   | 100 W    |

TERMINATION IMPEDANCE : 50 Ohms  
 TERMINATION AVG. POWER AT 25° C : 1 W per termination  
 3 W total power

**ELECTRICAL CHARACTERISTICS**

ACTUATOR : LATCHING  
 NOMINAL CURRENT AT 25° C (\*10%) : 320 mA / RESET : 960 mA (\*\*)  
 ACTUATOR VOLTAGE (Vcc) : 12V (10.2 to 13V) / NEGATIVE COMMON  
 TERMINALS : solder pins (250°C max./30 sec.)  
 TTL INPUTS (E) - High level : 2.2 to 5.5V / 800µA at 5V  
 - Low level : 0 to 0.8V / 20µA at 0.8V

**MECHANICAL CHARACTERISTICS**

CONNECTORS : SMA female per MIL-C 39012  
 LIFE : 2.000.000 cycles per position  
 SWITCHING TIME (nominal voltage;25° C) : < 15 ms  
 CONSTRUCTION : splashproof  
 WEIGHT : < 250 g

**ENVIRONMENTAL CHARACTERISTICS**

OPERATING TEMPERATURE RANGE (°C) : -40 , +85  
 STORAGE TEMPERATURE RANGE (°C) : -55 , +85

(\* : average power at 25° C per RF path)  
 (\*\* RESET : supply voltage time 1sec. max./duty cycle 10%)

4112-9212 This information is given as an indication. In the continual goal to improve our products, we reserve the right to make any modifications judged necessary

**DRAWING**

General tolerance: ± 0,5 mm

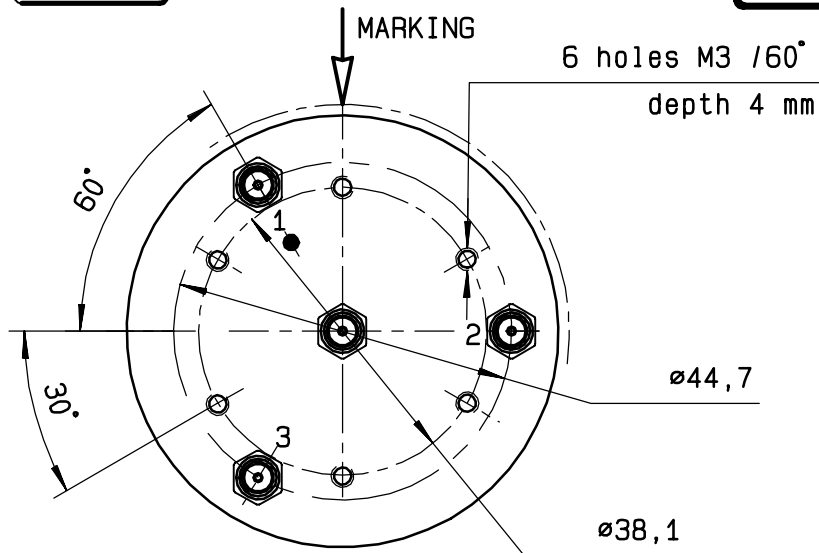

| TTL input | RF continuity  |
|-----------|----------------|
| RESET = 1 | All ports open |
| E1 = 1    | IN ↔ 1         |
| E2 = 1    | IN ↔ 2         |
| E3 = 1    | IN ↔ 3         |

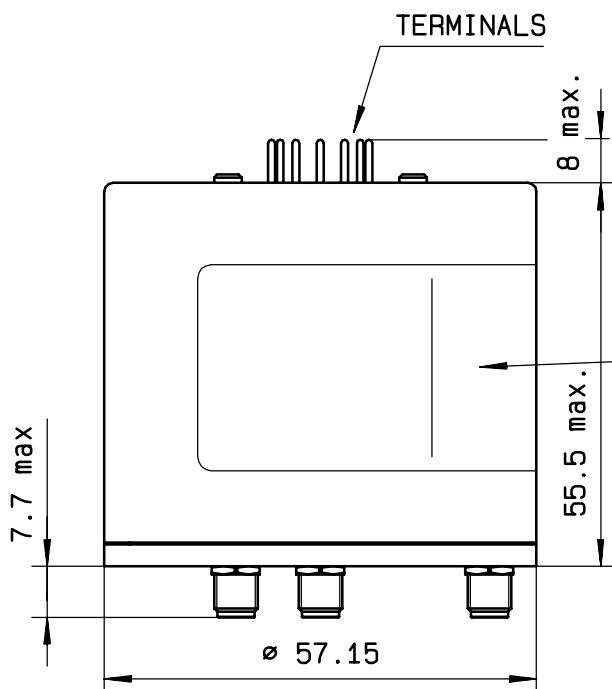

MARKING TOP VIEW (TERMINALS)

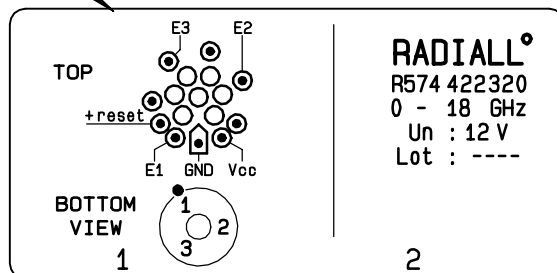

**SCHEMATIC DIAGRAM**

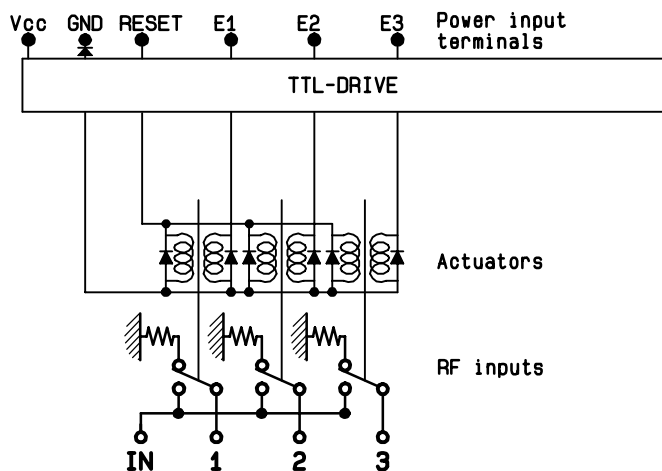

This information is given as an indication. In the continual goal to improve our products, we reserve the right to make any modifications judged necessary

4113-9212